

XARIOS 300

for your delivery vehicles

XARIOS 300

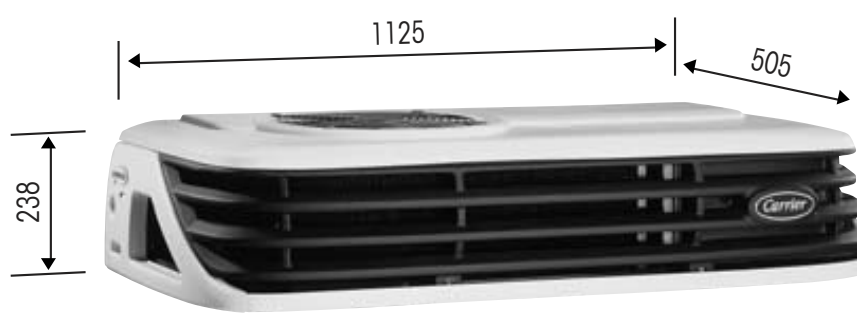

Road and standby version condenser

Weight: 66 kg

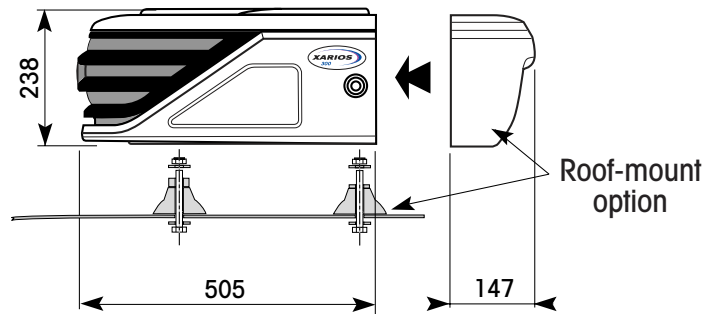

Roof-mount evaporator MXS 850

Weight: 19 kg



Vertical evaporator MXV 850

Weight: 17 kg

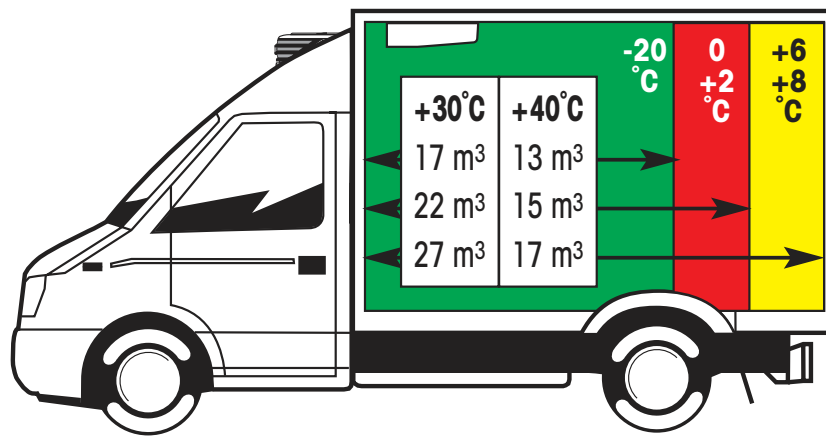

Certificate no.	M518 add2	M555
Road compressor	TM15 (2400 rpm)	TM15 (2400 rpm)
Evaporator	MXS 850	MXV 850
Refrigerant	R404A	R404A
Airflow (AMCA 21085)	840 m ³ /h	770 m ³ /h
Capacity at -20 / +30°C	1700 W	1655 W
Capacity at 0 / +30°C	2860 W	2730 W
Operation	<ul style="list-style-type: none"> • Road and standby 	
Standby voltage	<ul style="list-style-type: none"> • 400/3/50 Hz • 230/1/50 Hz 	
Road compressor	Consult our kit catalogue	
Standby compressor	CTD HB135-Rotary	
Defrost	Automatic or manual Defrost interval selection possible (1, 2, 3, 4, 5 or 6 hours)	
Standard equipment (S model)	<ul style="list-style-type: none"> • Xarios microprocessor control • Standby compressor hourmeter • Liquid injection for compressor reliability 	
Factory options	<ul style="list-style-type: none"> • Hot gas heating system (T model) • Operation on 12 or 24 VDC vehicles 	
Accessories or options	<ul style="list-style-type: none"> • Condenser roof-mount accessories • Condenser roof cut mounting kit • Road compressor mounting kit • 2,5 m or 6 m extension of evaporator connections • Drain water heater • Door switch 	